



Setup and Operation Guide

Integra INT-1221/1222

BACnet MSTP Communication

BACnet Communications

Once the client device has built its network table it is possible to start communicating with the product. The client system requires information as to which queries the product supports and the meaning of each return value. This information is available on the product Protocol Implementation Compliance Statement (PICS)

Alternatively, the client may gather the information from the Integra itself, using a BACnet ReadObject command. This returns the instance number of each supported object within the product.

The object table of the Integra is split into two sections, the first section lists all the "Analogue Value" objects within the Integra. Analogue Value objects may be read or written to and they are analogous to Holding Registers in Modbus. Each Analogue Value object is assigned an instance number which can be used by BACnet to read and write to it.

The second section lists all the "Analogue Inputs" within the Integra. Analogue Inputs are read only and are analogous to Modbus Input Registers. Again, each Analogue Input object is assigned an instance number which can be used by BACnet to read and write to it.

Supported Queries

This guide only includes the BACnet/MSTP query types which are supported by the product. The only relevant query types are those that read values from or write values to the Integra.

To read a parameter from the Integra, a "ReadProperty" query is required, with the object set to either "Analogue Input" or "Analogue Value" depending on what is required. The instance number is set according to the parameter to be read and the property identifier set to "Present Value". This query will obtain the most recent value for the Integra parameter.

To write to an Integra parameter, the value to be written is presented to a "WriteProperty" query is with the object set to "Analogue Value" with the instance number is set according to the parameter to be read and the property identifier set to "Present Value". This query will set the "Present Value" property of the Integra parameter to the new value.

BACnet systems should not attempt to address parameters whose instance value is not defined. Some parameters are reserved for factory use and selecting these may give unpredictable results.

Specification

The modules will communicate with Bacnet MSTP or Modbus RTU depending on the request.

Default Baud rate	38400
Stop Bits	1
Parity	None

Safety

The unit is designed in accordance with BS EN 61010-1:2001 (IEC 61010-1:2001) – Permanently connected use, Normal condition. Installation category III, pollution degree 2, double Insulation. Measurement Category III.

Maintenance

In normal use, no maintenance is needed. As appropriate for service conditions, isolate from electrical power, inspect the unit, and remove any dust or other foreign material present. Periodically check all connections for freedom from corrosion and screw tightness, particularly if vibration is present.

WARNING.

It is essential that the primary current is isolated BEFORE connecting or disconnecting the secondary current connections. **The unit is intended for panel mounting. Avoid mounting the unit where there is excessive vibration; in excessive direct sunlight; or outside a reasonably stable ambient temperature.**

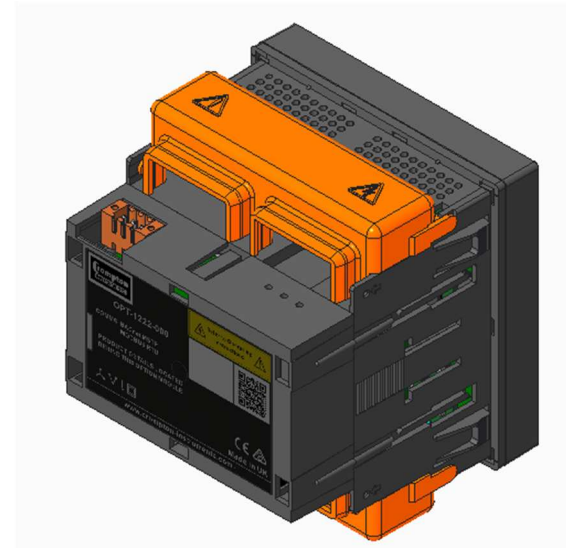

The menus provided for the BACnet MSTP option module are:

Installation

- Remove tab on rear label to expose connector
- Plug module on the rear of the product.

LED Status	Description
	Red LED indicates an error in the communication to the measurement unit.
	When the product is working correctly the Yellow LED will flash, when there is a problem the Yellow LED will continue to flash but the Red LED will illuminate.

Setup

Should setup of the option module be required, enter the setup screens by following the procedure below.

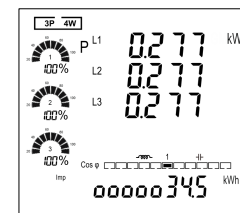

To enter setup mode, hold the and buttons for 3 seconds, until the password screen appears.

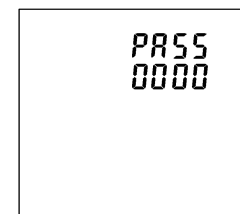

The setup is password-protected and must be entered before proceeding (default '0000').

Press 4 times.

If an incorrect password is entered, the product will exit the setup menu and return to the measurement screens. Entering the correct password will enter the setup mode.

BACnet MSTP / Modbus RTU Menus

To set and display the BACnet MSTP communication parameters on the product use the menu's below. The menus will only be available when the option module is connected.

Comms (cOnS)

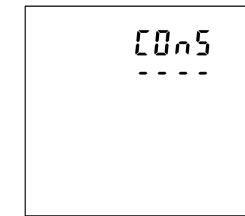

Use the up or down buttons to scroll through the available menu options until you get to the COnS screen.

Press to enter the Comms menu

To set or modify these parameters use

the up or down arrow buttons.

Press the button to enter each sub menu (shown below)

bAcn for BACnet communications.

Options for BACnet interface

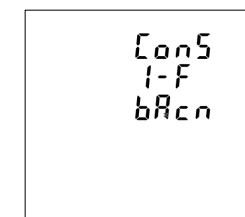

rtu for modbus RTU options.

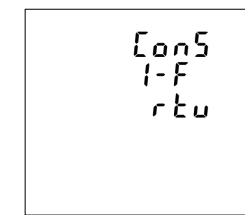

hAdd for Hardware Address (otherwise known as MAC address). Each value must be unique on the network. Set the number between 1 and 127 using the up or down arrow buttons.

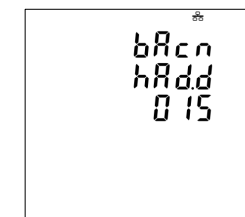

The MAC address of the Integra must be unique and appropriate for the network to which it is attached. The MAC address used will depend upon the local network and should be determined by the network administrator. Default is 001

ldt for Identity – this determines whether or not the "Instance" property uses the MAC address or a 22bit number. The options available in this menu are inSt – for 22 bit instance value used and nnAc – for MAC address.

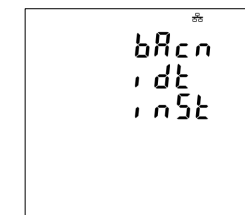

If the Identity (ldt) has been set to Instance this screen displays the value of the 22bit number which is set using the Bacnet interface. This cannot be changed in this menu.

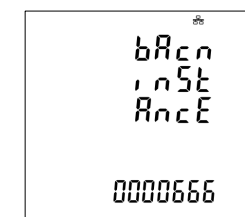

Warnings

- During normal operation, voltages hazardous to life may be present at some of the terminals of this unit.
- At voltages below that specified in the Range of Use the meter may shut down. However, voltages hazardous to life may still be present at some of the terminals of this unit.
- Installation and servicing should be performed only by qualified, properly trained personnel abiding by local regulations.
- Ensure all supplies are de-energised before attempting connection or other procedures.
- Terminals should not be user accessible after installation and external installation provisions must be sufficient to prevent hazards under fault conditions.
- This unit is not intended to function as part of a system providing the sole means of fault protection - good engineering practice dictates that any critical function be protected by at least two independent and diverse means.
- The unit does not have internal fuses therefore external fuses must be used for protection and safety under fault conditions.
- Never open-circuit the secondary winding of an energized current transformer.
- This product should only be operated with the CT secondary connections earthed.
- If this equipment is used in a manner not specified by the manufacturer, protection provided by the equipment may be impaired

This document provides operating, maintenance and installation instructions for the INT 1221/1222 BACnet MSTP option module. Each option module is sold separately and is installed by the user, following the details below.

Integra 1221/1222 options include a BACnet MSTP module for connection via RS485 to SCADA or Building Automation and Management systems running BACnet MSTP clients. The Integra 1221/1222 acts as a server device and waits to receive requests from a BACnet client that must conform to the BACnet MSTP Protocol within the command set defined below. For details on the protocol see the BACnet organisation website: <http://www.bacnet.org>

The Integra BACnet MSTP option module supports half duplex communication, initially at 38400baud, no parity 1 stop bit.

The module is fitted with a three-way screw terminal block to daisy-chain the BACnet communications cable. Standard RS485 communications cable should be used.

Note that with this interface option fitted, there are no other external communication protocols.

Protocol Implementation Conformance Statement (PICS)

Date	June 12 th 2012
Vendors Name	TE Electronics UK Limited
Product Name	Integra 12xx Digital Metering System
Application Software Version	001.000.016
Firmware version	1
BACnet Protocol Version	1.1
Product Description	The Integra12xx is a multi-function digital metering instrument offering measurement, display and communication of many electrical parameters. The Integra 12xx is programmable via simple configuration menu structure.
BACnet Standardized Device Profile (Annex L)	BACnet Application Specific Controller (B-ASC)
BACnet Interoperability Building Blocks Supported (Annex K)	DS-RP-B, DS-WP-B, DM-DDB-B, DM-DOB-B, DM-DCC-B
Segmentation Capability	Not supported
Device Object	
Optional Properties Supported	None
Proprietary Properties Supported	BAUD RATE (propt Identifier 9600)
Writable Properties	BAUD RATE
Property Range Restrictions	38400
Analogue Input Object	
Optional Properties Supported	Description
Writable Properties	None
Property Range Restrictions	n/a
Analogue Value Object	
Optional Properties Supported	Description
Writable Properties	Present Value
Property Range Restrictions	Refer to Analogue Value Objects Section
Data Link Layer Options	MS/TP slave (Clause 9) baud rates(s): 9600, 19200, 38400
Device Address Binding	
Networking Options	None
Character Set Supported	ANSI X3.4

Analogue Input Objects

The measurement parameters of the Integra meter are represented in the BACnet world as Analogue Input Values. The following table outlines what is available from each Analogue Input instance.

Instance Number	Object Name	Description	Units
0	V1	Phase 1 line to neutral voltage	volts (0x5)
1	V2	Phase 2 line to neutral voltage	volts (0x5)
2	V3	Phase 3 line to neutral voltage	volts (0x5)
3	A1	Line 1 current	amperes (0x3)
4	A2	Line 2 current	amperes (0x3)
5	A3	Line 3 current	amperes (0x3)
6	P1	Phase 1 power	watts (0x2F)
7	P2	Phase 2 power	watts (0x2F)
8	P3	Phase 3 power	watts (0x2F)
9	VA1	Phase 1 VA	volt_amperes (0x8)
10	VA2	Phase 2 VA	volt_amperes (0x8)
11	VA3	Phase 3 VA	volt_amperes (0x8)
12	VAR1	Phase 1 VAR	volt_amperes_reactive (0xB)
13	VAR2	Phase 2 VAR	volt_amperes_reactive (0xB)
14	VAR3	Phase 3 VAR	volt_amperes_reactive (0xB)
15	PF1	Phase 1 power factor	power_factor (0xF)
16	PF2	Phase 2 power factor	power_factor (0xF)
17	PF3	Phase 3 power factor	power_factor (0xF)
18	PA1	Phase 1 phase angle	degrees_phase (0xE)
19	PA2	Phase 2 phase angle	degrees_phase (0xE)
20	PA3	Phase 3 phase angle	degrees_phase (0xE)

21	VLNAvg	Average line to neutral voltage	volts (0x5)
22	AAvg	Average line current	amperes (0x3)
23	ASum	Sum of line currents	amperes (0x3)
24	PSum	Sum of phase powers	watts (0x2F)
25	VASum	Sum of phase VAs	volt_amperes (0x8)
26	VARSum	Sum of phase VARs	volt_amperes_reactive (0xB)
27	PFTot	Total system power factor	power_factor (0xF)
28	PATot	Total system phase angle	degrees_phase (0xE)
29	Frq	System frequency	hertz (0x1B)
30	ImpWh	Import Watt hours	watt_hours (0x12)
31	ExpWh	Export Watt hours	watt_hours (0x12)
32	ImpVARh	Import VAR hours	Not an ASHRAE defined value (0xF2)
33	ExpVARh	Export VAR hours	Not an ASHRAE defined value (0xF2)
34	VAh	VA hours	Not an ASHRAE defined value (0xEF)
35	PSumDmd	Import power sum demand	watts (0x2F)
36	PSumDmdMax	Maximum import power sum demand	watts (0x2F)
37	VASumDmd	VA sum demand	volt_amperes (0x8)
38	VASumDmdMax	Maximum VA sum demand	volt_amperes (0x8)
39	ASumDmd	Current sum demand	amperes (0x3)
40	ASumDmdMax	Maximum current sum demand	amperes (0x3)
41	V1Max	Maximum phase 1 line to neutral voltage	volts (0x5)
42	V1Min	Minimum phase 1 line to neutral voltage	volts (0x5)
43	V2Max	Maximum phase 2 line to neutral voltage	volts (0x5)
44	V2Min	Minimum phase 2 line to neutral voltage	volts (0x5)
45	V3Max	Maximum phase 3 line to neutral voltage	volts (0x5)
46	V3Min	Minimum phase 3 line to neutral voltage	volts (0x5)
47	A1Max	Maximum line 1 current	amperes (0x3)
48	A1Min	Minimum line 1 current	amperes (0x3)
49	A2Max	Maximum line 2 current	amperes (0x3)

50	A2Min	Minimum line 2 current	amperes (0x3)
51	A3Max	Maximum line 3 current	amperes (0x3)
52	A3Min	Minimum line 3 current	amperes (0x3)
53	VLNAvgMax	Maximum average line to neutral voltage	volts (0x5)
54	VLNAvgMin	Minimum average line to neutral voltage	volts (0x5)
55	AAvgMax	Maximum average line current	amperes (0x3)
56	AAvgMin	Minimum average line current	amperes (0x3)
57	ASumMax	Maximum sum of line currents	amperes (0x3)
58	ASumMin	Minimum sum of line currents	amperes (0x3)
59	P1Max	Maximum phase 1 power	watts (0x2F)
60	P1Min	Minimum phase 1 power	watts (0x2F)
61	P2Max	Maximum phase 2 power	watts (0x2F)
62	P2Min	Minimum phase 2 power	watts (0x2F)
63	P3Max	Maximum phase 3 power	watts (0x2F)
64	P3Min	Minimum phase 3 power	watts (0x2F)
65	PSumMax	Maximum sum of phase powers	watts (0x2F)
66	PSumMin	Minimum sum of phase powers	watts (0x2F)
67	VAR1Max	Maximum phase 1 VARs	volt_amperes_reactive (0xB)
68	VAR1Min	Minimum phase 1 VARs	volt_amperes_reactive (0xB)
69	VAR2Max	Maximum phase 2 VARs	volt_amperes_reactive (0xB)
70	VAR2Min	Minimum phase 2 VARs	volt_amperes_reactive (0xB)
71	VAR3Max	Maximum phase 3 VARs	volt_amperes_reactive (0xB)
72	VAR3Min	Minimum phase 3 VARs	volt_amperes_reactive (0xB)
73	VARSumMax	Maximum sum of phase VARs	volt_amperes_reactive (0xB)
74	VARSumMin	Minimum sum of phase VARs	volt_amperes_reactive (0xB)
75	VA1Max	Maximum phase 1 VAs	volt_amperes (0x8)
76	VA1Min	Minimum phase 1 VAs	volt_amperes (0x8)
77	VA2Max	Maximum phase 2 VAs	volt_amperes (0x8)
78	VA2Min	Minimum phase 2 VAs	volt_amperes (0x8)
79	VA3Max	Maximum phase 3 VAs	volt_amperes (0x8)
80	VA3Min	Minimum phase 3 VAs	volt_amperes (0x8)

81	VASumMax	Maximum sum of phase VAs	volt_amperes (0x8)
82	VASumMin	Minimum sum of phase VAs	volt_amperes (0x8)
83	FrqMax	Maximum system voltage frequency	hertz (0x1B)
84	FrqMin	Minimum system voltage frequency	hertz (0x1B)
85	V12	Voltage line 1 to line 2	volts (0x5)
86	V23	Voltage line 2 to line 3	volts (0x5)
87	V31	Voltage line 3 to line 1	volts (0x5)
88	VLLAvg	Average line to line voltage	volts (0x5)
89	V12Max	Maximum line 1 to line 2 voltage	volts (0x5)
90	V12Min	Minimum line 1 to line 2 voltage	volts (0x5)
91	V23Max	Maximum line 2 to line 3 voltage	volts (0x5)
92	V23Min	Minimum line 2 to line 3 voltage	volts (0x5)
93	V31Max	Maximum line 3 to line 1 voltage	volts (0x5)
94	V31Min	Minimum line 3 to line 1 voltage	volts (0x5)
95	VLLAvgMax	Maximum average line to line voltage	volts (0x5)
96	VLLAvgMin	Minimum average line to line voltage	volts (0x5)
97	ANeu	Neutral current	amperes (0x3)
98	ANeuMax	Maximum neutral current	amperes (0x3)
99	ANeuMin	Minimum neutral current	amperes (0x3)
100	ANDmd	Neutral current demand	amperes (0x3)
101	ANDmdMax	Maximum neutral current demand	amperes (0x3)
102	V1THD	Phase 1 line to neutral voltage THD. *	percent (0x62)
103	V2THD	Phase 2 line to neutral voltage THD. *	percent (0x62)
104	V3THD	Phase 3 line to neutral voltage THD. *	percent (0x62)
105	A1THD	Line 1 current THD	percent (0x62)
106	A2THD	Line 2 current THD	percent (0x62)
107	A3THD	Line 3 current THD	percent (0x62)
108	VTHDAvg	Average line to neutral voltage THD. *	percent (0x62)

109	ATHDAvg	Average line current THD	percent (0x62)
110	HRun	Hours run at over minimum load	percent (0x62)
111	PFTot	Total system power factor, times minus one	percent (0x62)
112	A1Dmd	Line 1 current demand	amperes (0x3)
113	A2Dmd	Line 2 current demand	amperes (0x3)
114	A3Dmd	Line 3 current demand	amperes (0x3)
115	A1DmdMax	Maximum line 1 current demand	amperes (0x3)
116	A2DmdMax	Maximum line 2 current demand	amperes (0x3)
117	A3DmdMax	Maximum line 3 current demand	amperes (0x3)
118	PRot	Phase rotation sequence	percent (0x62)
119	VLNBal	Line to neutral voltage out of balance	percent (0x62)
120	ABal	Line current out of balance	percent (0x62)
121	VLNBalMax	Maximum line to neutral voltage out of balance	percent (0x62)
122	VLNBalMin	Minimum line to neutral voltage out of balance	percent (0x62)
123	ABalMax	Maximum line current out of balance	percent (0x62)
124	ABalMin	Minimum line current out of balance	percent (0x62)
125	PF1Max	Maximum phase 1 power factor	percent (0x62)
126	PF1Min	Minimum phase 1 power factor	percent (0x62)
127	PF2Max	Maximum phase 2 power factor	percent (0x62)
128	PF2Min	Minimum phase 2 power factor	percent (0x62)
129	PF3Max	Maximum phase 3 power factor	percent (0x62)
130	PF3Min	Minimum phase 3 power factor	percent (0x62)
131	PFTotMax	Maximum total system power factor	percent (0x62)
132	PFTotMin	Minimum total system power factor	percent (0x62)
133	PATotMax	Maximum total system phase angle	degrees_phase (0xE)
134	PATotMin	Minimum total system phase angle	degrees_phase (0xE)

135	V1THDMax	Maximum phase 1 line to neutral voltage THD. *	percent (0x62)
136	V1THDMin	Minimum phase 1 line to neutral voltage THD. *	percent (0x62)
137	V2THDMax	Maximum phase 2 line to neutral voltage THD. *	percent (0x62)
138	V2THDMin	Minimum phase 2 line to neutral voltage THD. *	percent (0x62)
139	V3THDMax	Maximum phase 3 line to neutral voltage THD. *	percent (0x62)
140	V3THDMin	Minimum phase 3 line to neutral voltage THD. *	percent (0x62)
141	A1THDMax	Maximum line 1 current THD	percent (0x62)
142	A1THDMin	Minimum line 1 current THD	percent (0x62)
143	A2THDMax	Maximum line 2 current THD	percent (0x62)
144	A2THDMin	Minimum line 2 current THD	percent (0x62)
145	A3THDMax	Maximum line 3 current THD	percent (0x62)
146	A3THDMin	Minimum line 3 current THD	percent (0x62)
147	P1Dmd	Import phase 1 power demand	watts (0x2F)
148	P2Dmd	Import phase 2 power demand	watts (0x2F)
149	P3Dmd	Import phase 3 power demand	watts (0x2F)
150	P1DmdMax	Import phase 1 power demand maximum	watts (0x2F)
151	P2DmdMax	Import phase 2 power demand maximum	watts (0x2F)
152	P3DmdMax	Import phase 3 power demand maximum	watts (0x2F)
153	VA1Dmd	Phase 1 VA demand	volt_amperes (0x8)
154	VA2Dmd	Phase 2 VA demand	volt_amperes (0x8)
155	VA3Dmd	Phase 3 VA demand	volt_amperes (0x8)
156	VA1DmdMax	Phase 1 VA demand maximum	volt_amperes (0x8)
157	VA2DmdMax	Phase 2 VA demand maximum	volt_amperes (0x8)
158	VA3DmdMax	Phase 3 VA demand maximum	volt_amperes (0x8)
159	VTHDAvg	Maximum average line to neutral voltage THD. *	percent (0x62)

160	VTHDAvg	Minimum average line to neutral voltage THD. *	percent (0x62)
161	ATHDAvg	Maximum average line current THD	percent (0x62)
162	ATHDAvg	Minimum average line current THD	percent (0x62)
163	PA1Max	Maximum phase 1 phase angle	degrees_phase (0xE)
164	PA2Max	Maximum phase 2 phase angle	degrees_phase (0xE)
165	PA3Max	Maximum phase 3 phase angle	degrees_phase (0xE)
166	PA1Min	Minimum phase 1 phase angle	degrees_phase (0xE)
167	PA2Min	Minimum phase 2 phase angle	degrees_phase (0xE)
168	PA3Min	Minimum phase 3 phase angle	degrees_phase (0xE)
169	V1 Vector Angle	V1 vector angle	degrees_phase (0xE)
170	V2 Vector Angle	V2 vector angle	degrees_phase (0xE)
171	V3 Vector Angle	V3 vector angle	degrees_phase (0xE)
172	A1 Vector Angle	A1 vector angle	degrees_phase (0xE)
173	A2 Vector Angle	A2 vector angle	degrees_phase (0xE)
174	A3 Vector Angle	A3 vector angle	degrees_phase (0xE)

Note: The BACnet standard does not specify an enumerated value for some of the engineering units used for some instances of Analogue Input

Object: The following table identifies the parameters and the non-standard enumerations used (The system administrator may be able to set up the system to identify these special codes and report the correct text for the associated units:

Proprietary	Enumerated Value within BACnet	Used With
Volt-Ampere hours	257 (0x101)	VA Hours (Analogue Input Instance number 34)

Analogue Value Object

The configuration and user setting parameters of the Integra meter are represented in the BACnet world as Analogue Input values.

The following table outlines what is available from each Analogue Value object instance.

Some parameters are read only and can't be changed.

Some writeable values may only accept a limit set of values or maybe password protected.

Instance Number	Name	Description	Units
0	Dmd	Demand Time – Write 0 to reset demand period Mode: Read/Write	Minutes
1	Dmd Period	Demand time (in minutes) supported by the instrument. Other values ignored. Range: 8, 15, 20, 30, 60 Mode: Read/Write	Minutes
2	Sys Volts	System Voltage – In a PT/VT connected system represents the PT/VT primary voltage. In a direct connect system this parameter should be set the same as the secondary voltage. Range: 1V to 400kV Mode: Read/Write (Protected)	Volts
3	Sys Current	System Current – represents the CT primary current Range: 1A to 9999A Mode: Read/Write (Protected)	Amperes
4	SYS Type	System Type – the system mode the instrument is operating in Range: 1 (1ph2w), 2 (3ph3w), 3 (3ph4w) Mode: Read/Write (Protected)	
5	Relay Pulse Width	The width of the relay pulse in multiples of 20 ms. Only pulse widths of 3 (60ms), 5 (100ms) or 10 (200ms) are supported. Mode: Read/Write	
6	Relay Pulse Divisor	Write 0 to reset the energy readings other values will be ignored. Reading will always return zero. Mode: Read/Write	
7	Password	A rate adjustment of the relay output. For example, a pulse rate of 1 used with the parameter 'import kWh' would cause the relay to pulse at a rate of 1 kWh import. The rate is automatically limited to 2 pulses/second at 144% of rated power Range: 1, 10, 100, 1000 Mode: Read/Write	
8	Sys Power	Entering the correct password value will 'unlock' the writing of some of the other analogue value objects. Range: 0000 to 9999 Mode: Read/Write	Watts
9	Hi Serial	The maximum system power based on the values of system current, system voltage and the system type of the instrument. Mode: Read	
10	Lo Serial	0 to 16,777,215 The high order digits of the instruments serial number. Mode: Read	
11	Selected Energy Param	The number of the relay selected for editing/review in analogue value object number 15. For BACnet MSTP this value is meaningless as Relay Outputs are not supported. Range: 1 to 2 Mode: Read/Write	
12	Hrs Run VA	The proportion of the rated VA that is necessary for the hours run parameter to start accumulating time. A value of 0.1 would represent 10% of rated VA. A value of 0.0 will cause the hours run counter to operate continuously whilst power to the instrument is provided. to 0.5 in steps of 0.002 Write 0 to clear the hours run counter Mode: Read/Write	
13	Reset Parameter		
14	Secondary Volts	Indicates the voltage on the VT secondary when the voltage on the VT primary is equal to the value of System Volts. The value of this register can be set to between the minimum and maximum instrument input voltage. Range: Min Vin to Max Vin Mode: Read/Write (Protected)	
15	Energy Prefix	Energy Units Prefix, unit, k, M or G	Volts
16	BACnet Baud Rate	Controls the speed of communications over the BACnet MS/TP link. Reading provides the Baud Rate presently in use. Writing changes the Baud Rate. Only values of 9600, 19200 and 38400 are accepted and the unit has to be power cycled for the rate change to take effect. Default is 38400	



Mechanics

Material UL 94-V0

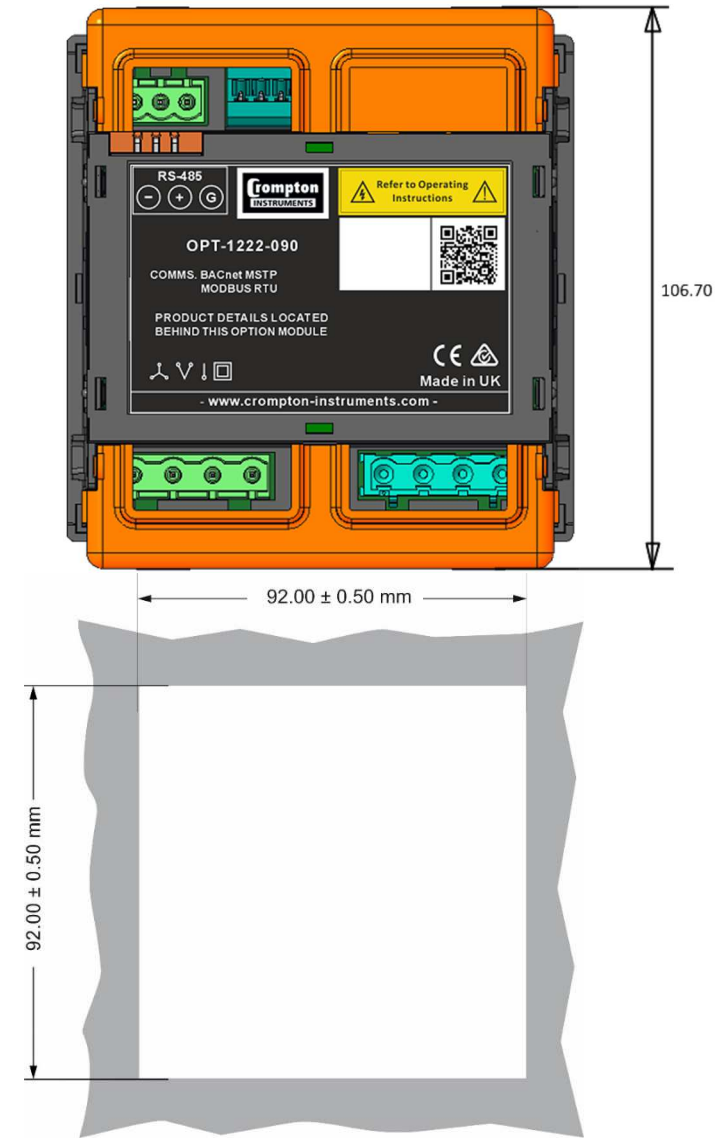
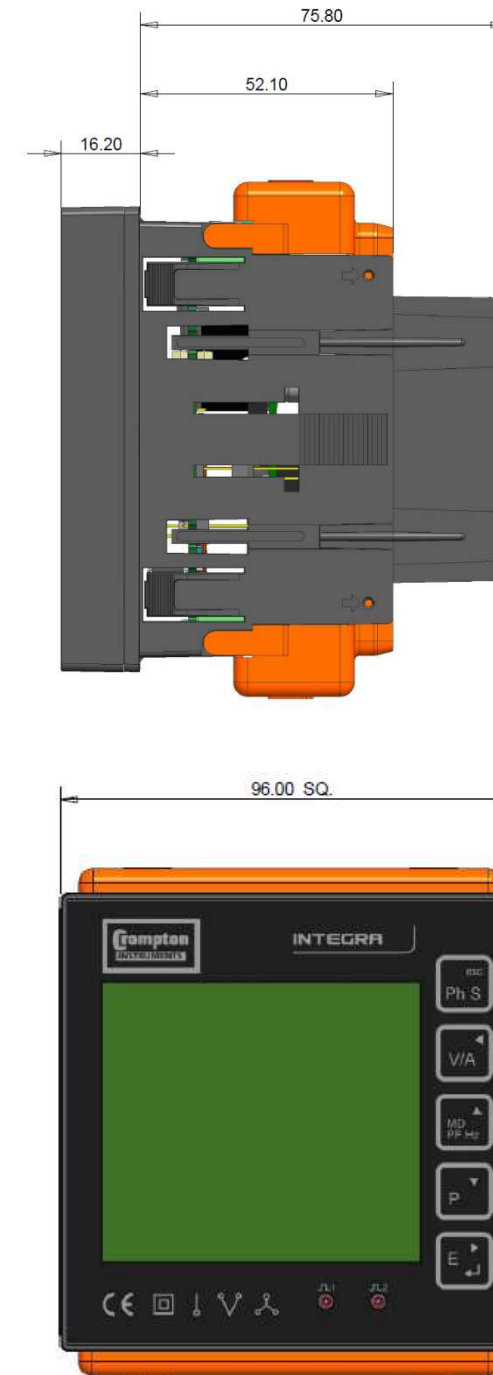
Dimensions



Explanation of Symbols

-  Refer to manual
-  Danger of electric shock
-  Do not discard

While TE has made every reasonable effort to ensure the accuracy of the information in this catalogue, TE does not guarantee that it is error-free, nor does TE make any other representation, warranty or guarantee that the information is accurate, correct, reliable or current. TE reserves the right to make any adjustments to the information contained herein at any time without notice. TE expressly disclaims all implied warranties regarding the information contained herein, including, but not limited to, any implied warranties of merchantability or fitness for a particular purpose. The dimensions in this catalogue are for reference purposes only and are subject to change without notice. Specifications are subject to change without notice. Consult TE for the latest dimensions and design specifications. TE connectivity (logo), TE (logo) and TE Connectivity are trademarks of the TE Connectivity Ltd. family of companies. Crompton is a trademark of Crompton Parkinson and is used by TE Connectivity under a licence. Other logos, product and company names mentioned herein may be trademarks of their respective owners

TE Energy – innovative and economical solutions for the electrical power industry: cable accessories, connectors & fittings, insulators & insulation, surge arresters, switching equipment, street lighting, power measurement and control.

Tyco Electronics UK Ltd
TE Energy
Freebournes Road
Witham, Essex CM8 3AH
Phone: +44 (0)870 870 7500
Fax: +44 (0)870 240 5289
Email: Crompton.info@te.com
www.crompton-instruments.com

